

SVQ-4GD-OCIT Infrared Hand-held Remote Control

Operating Instructions Please Leave for Occupant

Description

The SVQ-4GD-OCIT Hand-held Remote Control provides control of Sivoia® or Sivoia QED™ window shades. The user can individually select up to four groups of shades by pressing a window group button (1-4). Each group of shades can be controlled individually or all groups (1-4) can be selected for control of all groups simultaneously. Each window group (1-4) can consist of one or more shades. For Sivoia QED Electronic Drive Units (EDUs), please refer to the Sivoia QED Wiring and Programming Guide or the Sivoia QED Technical Reference Guide for the setup procedure. For Sivoia Electronic Drive Units (EDUs), please refer to the Sivoia Electronic Drive Unit installation instructions or the Sivoia Technical Reference Guide for the setup procedure.

Operation

Point the Infrared Hand-held Remote Control at the Sivoia or Sivoia QED IR receiver.

- Select the window group(s). Press the appropriate window group button, 1, 2, 3, 4 or All (default is All window groups).
- Select the shade(s). Press the appropriate shade button, Front, Rear or Both (default is Both shades).
- Operate the shade(s). Select the desired function by pressing the appropriate button, Open, Close, Raise or Lower.

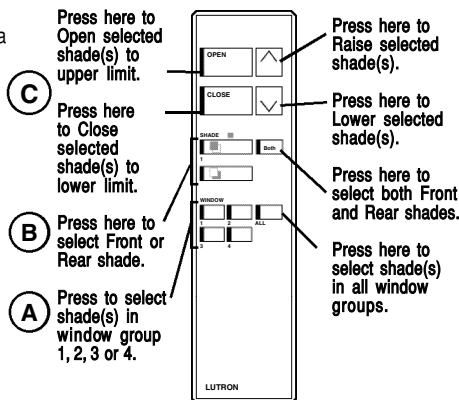

Note: Pressing any button while the shade is moving will stop the shade.

Battery Replacement

The SVQ-4GD-OCIT Infrared Hand-held Remote Control uses 3 AAA batteries which are pre-installed (see diagram). For best results use **Energizer** brand alkaline batteries. Do not use NiCad batteries.

To replace batteries:

- Remove the battery cover.
- Replace with 3 size AAA alkaline batteries as shown.
- Replace the battery cover.

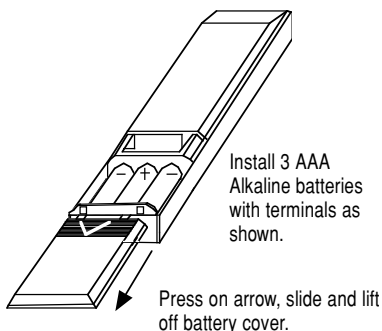

The Infrared Hand-held Remote Control is safe for use around baths and spas.



DO NOT SUBMERGE IN WATER.

Troubleshooting

Problem	Causes	Remedies
Infrared Hand-held Remote Control has no effect on the Electronic Drive Unit (EDU).	Electronic Drive Unit (EDU) power is OFF.	Restore power.
	Dead, low, or no batteries in the Infrared Hand-held Remote Control.	Install new batteries.
	Infrared Hand-held Remote Control is too far away from the IR receiver.	Try moving closer to the shade(s) you wish to control. If an IR receiver is installed on the Electronic Drive Unit (EDU), verify that it is properly installed and the IR receiver is not obstructed (e.g. by curtains, fascia, drapes).
	Batteries inserted incorrectly.	Install batteries per diagram on the first page.

Technical Assistance

Lutron Shading Solutions by VIMCO
11520 Sun Shade Lane
Ashland, Virginia 23005

www.lutron.com

24/7 service and support:

call: 1-800-446-1503

fax: 1-804-752-3366

email: shadinginfo@lutron.com

©2004 LUTRON Electronics Co., Inc.

Limited Warranty

Lutron Shading Solutions by VIMCO offers an 8-year limited warranty for our shading systems. Please contact customer service or visit our website for a complete warranty statement.

Lutron Shading Solutions by VIMCO reserves the right to make improvements or changes to these products without prior notice. Although every attempt is made to ensure that this information is accurate and up to date, please check with Lutron Shading Solutions by VIMCO to confirm product availability, the latest specifications, and suitability for your application.

These products may be covered under one or more of the following U.S. patents: 5,467,266; 5,671,387; 5,848,634; 6,100,659; DES 317,593; DES 344,068; DES 370,663; DES 378,814; DES 387,736; DES 391,924; DES 396,448; DES 437,585; and corresponding foreign patents. US and foreign patents pending.

Lutron, the Sunburst logo, and Sivoia are registered trademarks, and Sivoia QED and "Lutron controls your light" are trademarks of Lutron Electronics Co., Inc.