

## Operating Instructions Please Leave for Occupant

## SVQ-3PIT Infrared Hand-held Remote Control

### Description

The SVQ-3PIT Infrared Hand-held Remote Control provides remote blind operation from the palm of your hand. The Infrared Hand-held Remote Control transmits signals to Sivoia® or Sivoia QED™ Electronic Drive Units (EDUs). The Infrared Hand-held Remote Control is compatible with learnable remote controls. To access advanced features, please refer to the Sivoia QED Wiring and Programming Guide or the Sivoia QED Technical Reference Guide.

### Operation

Point the Infrared Hand-held Remote Control at the Sivoia or Sivoia QED IR receiver, then use the buttons as shown below.

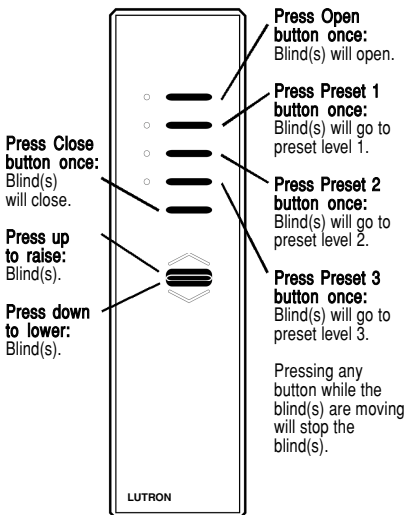

#### Easy Preset Programming

1. Adjust blind(s) to desired position.
2. Point the SVQ-3PIT at any of the *Sivoia* or *Sivoia QED* IR receivers.
3. Press and hold the desired Preset button for 5 seconds.



**Note:** Pressing any button while the blind is moving will stop the blind.

### Battery Replacement

The SVQ-3PIT Infrared Hand-held Remote Control uses 3 AAA batteries which are pre-installed (see diagram). For best results use **Energizer** brand alkaline batteries. Do not use NiCad batteries.

#### To replace batteries:

1. Remove the battery cover.
2. Replace with 3 size AAA alkaline batteries as shown.
3. Replace the battery cover.

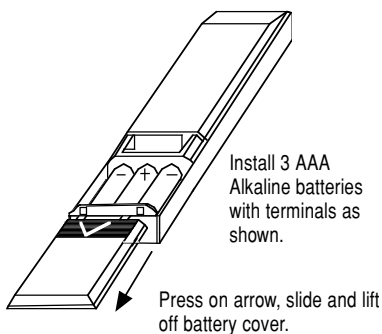

The Infrared Hand-held Remote Control is safe for use around baths and spas.



DO NOT SUBMERGE IN WATER.

## Troubleshooting

Problem	Causes	Remedies
Infrared Hand-held Remote Control has no effect on the Electronic Drive Unit (EDU).	Electronic Drive Unit (EDU) power is OFF.	Restore power.
	Dead, low, or no batteries in the Infrared Hand-held Remote Control.	Install new batteries.
	Infrared Hand-held Remote Control is too far away from the IR receiver.	Try moving closer to the blind(s) you wish to control.  If an IR receiver is installed on the Electronic Drive Unit (EDU), verify that it is properly installed and the IR receiver is not obstructed (e.g. by curtains, fascia, drapes).
	Batteries inserted incorrectly.	Install batteries per diagram.
Presets are not being saved.	The desired preset button was held for less than 5 seconds.	Press and hold the desired preset button for at least 5 seconds.
	Presets are locked.	Unlock presets. Refer to the setup guide that accompanied the EDU.

## Technical Assistance

Lutron Shading Solutions by VIMCO  
11520 Sun Shade Lane  
Ashland, Virginia 23005

www.lutron.com

24/7 service and support:  
call: 1-800-446-1503  
fax: 1-804-752-3366

email: shadinginfo@lutron.com

London 44.171.702.0657  
fax: 44-207-480-6899

©2004 LUTRON Electronics Co., Inc.

## Limited Warranty

Lutron Shading Solutions by VIMCO offers an 8-year limited warranty for our shading systems. Please contact customer service or visit our website for a complete warranty statement.

Lutron Shading Solutions by VIMCO reserves the right to make improvements or changes to these products without prior notice. Although every attempt is made to ensure that this information is accurate and up to date, please check with Lutron Shading Solutions by VIMCO to confirm product availability, the latest specifications, and suitability for your application.

These products may be covered under one or more of the following U.S. patents: 5,467,266; 5,671,387; 5,848,634; 6,100,659; 6,201,364; 6,313,588; 6,346,781; 6,497,207; DES 310,349; DES 370,663; and corresponding foreign patents. US and foreign patents pending.

Lutron, the Sunburst logo, and Sivoia are registered trademarks, and Sivoia QED and "Lutron controls your light" are trademarks of Lutron Electronics Co., Inc.