

## QS | Link power supply

The QS Link power supply (QSPS-P1-1-50/ QSPS-P2-1-50/ QSPS-P3-1-50) is a 24 V<sub>DC</sub> plug in power supply that is used with Lutron® QS lighting or shading devices.

The Link power supply plugs into a standard receptacle. The power supply is protected electronically in the event of a miswire, and will automatically reset when wiring is corrected.

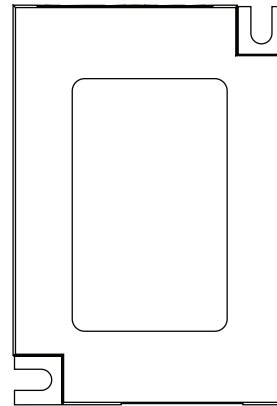
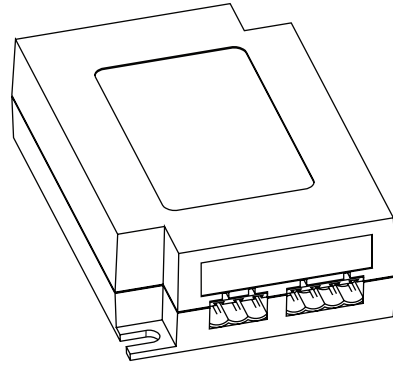

### Features



- 24 V<sub>DC</sub> supply that provides power to shades, drapery drive units, keypads, and accessories
- Simple wiring scheme uses 4-conductor, low voltage link to provide power and communication for QS electronic drive units (EDUs), see Touch® QS keypads and QS integration interfaces
- Mounting tabs and small size allow for discrete installation
- Universal input voltage (100-240 VAC) enables global specification

QSPS-P1-1-50  
Link power supply

Job Name:	Model Numbers:
Job Number:	

## Specifications

Input Voltage	100-240 V~
Input current (MAX)	1 A
Output Voltage	24 V==
Operating Frequency	50/60 Hz
ESD Protection	(+/-) 16 kV
Miswire Protection	Electronic Automatic Reset
Input Wiring	Available with 3 types of line cords. All 6 ft (1.8 m) Plugs into standard receptacle

- QSPS-P1-1-50**  NEMA 5-15 Plug
- QSPS-P2-1-50**  CEE 7/7 Plug
- QSPS-P3-1-50**  BS 1363 Plug

QS Link Wiring	<p>4-conductor (power and communication) +24 V, COM, MUX, <math>\overline{\text{MUX}}</math></p> <p>3-conductor (communication pass-through) COM, MUX, <math>\overline{\text{MUX}}</math></p>
Output connections	<p>Detachable terminal blocks 12-26 AWG (4-0.15 mm<sup>2</sup>) stranded, twisted/shielded</p>
Weight	0.3 lb (0.14 kg)
Regulatory	<p>UL (1310 CLASS2) CE (IEC 61558) CUL (CSA C22.2 #223)</p>

Job Name:	Model Numbers:
Job Number:	

### Dimensions

- QSPS-P1-1-50
- QSPS-P2-1-50
- QSPS-P3-1-50

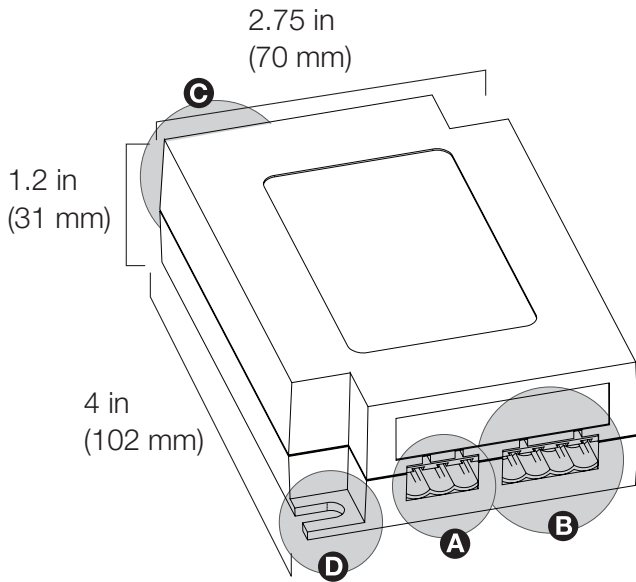

- A** 3-pin connector  
Communication to additional Power supplies
- B** 4-pin connector  
Power and Communication to QS shade or keypads
- C** Line voltage input
- D** Mounting tabs

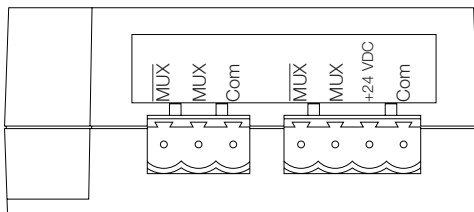

Job Name:	Model Numbers:
Job Number:	

## System Wiring Overview: QS Link power supply

**Example:** Powering one shade / drapery drive unit  
(max of one shade / drapery drive unit per output of a power supply)

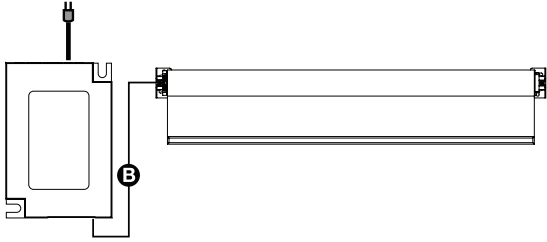

**Example:** Powering keypads

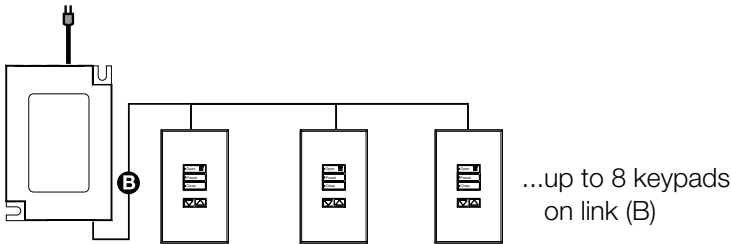

**Example:** Connecting to a *GRAFIK Eye*® QS (**Note:** *GRAFIK Eye* QS powered from line voltage)

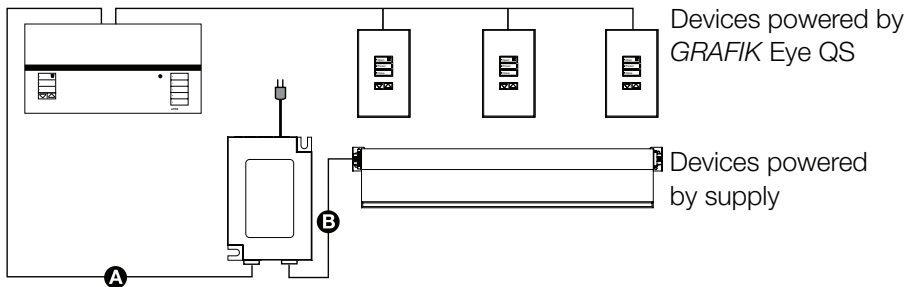

**Example:** Connecting to a *GRAFIK Eye* QS (**Note:** *GRAFIK Eye* QS powered from line voltage)

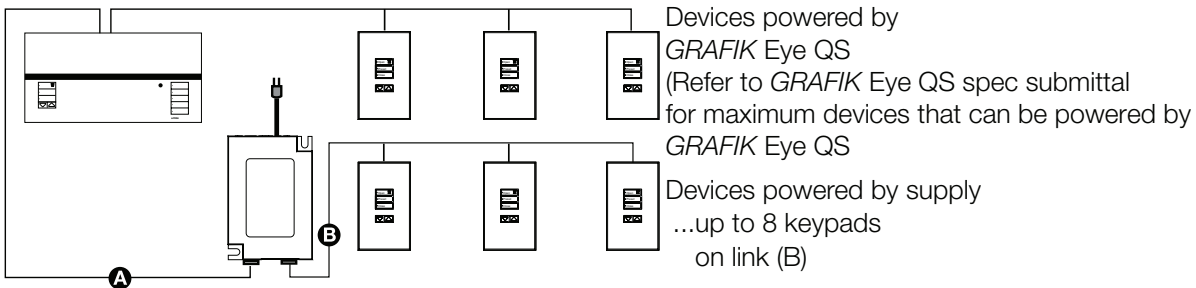

- A** Communication link (3 conductor)  
Communications used to connect power supplies to each other or to *GRAFIK Eye* QS  
12-26 AWG (4-0.15 mm<sup>2</sup>) standard, twisted/shielded
- B** Power and communication link (4 conductor)  
Provides power and communication to QS shades or keypads  
12-26 AWG (4-0.15 mm<sup>2</sup>) standard, twisted/shielded

Job Name:	Model Numbers:
Job Number:	

## QS Link Wiring

### Link Rules

The following link rules must be observed for proper operation.

- Use only cable with at least one twisted/shielded pair for communications (MUX and MUX)
- Total length of power supply link (A) wire plus device link (B) wire in entire system must be less than 2000 ft (609 m)

Maximum devices powered from one QSPS-PX-1-50		Total wire length of link (B) based on wire gauge		
Shades	Controls	12 AWG (4 mm <sup>2</sup> ) QSH-CBL-L-500 QSH-CBLP-L-500	16 AWG (1.5 mm <sup>2</sup> ) QSH-CBL-M-500 QSH-CBLP-M-500	18 AWG (1 mm <sup>2</sup> ) GRX-CBL-346S-500
1 Sivoia QS shade/drapery drive unit	Up to 1 seeTouch® QS keypad	250 ft (75 m)	100 ft (30 m)	50 ft (15 m)
None	Up to 8 seeTouch® QS keypads*	1200 ft (350 m)	500 ft (150 m)	300 ft (90 m)

**OR**

\* 2 seeTouch QS keypads may be exchanged for:

1 Ethernet & RS232 Control Interface (QSE-CI-NWK-E)

1 Contact Closure Input /Output Interface (QSE-IO)

Job Name:	Model Numbers:
Job Number:	

## Technical and Sales Assistance

### WORLD HEADQUARTERS

Lutron Electronics Co., Inc.  
7200 Suter Road  
Coopersburg, PA 18036  
United States  
Tel: +1.610.282.3800  
Fax: +1.610.282.1243

### ASIAN HEADQUARTERS

Lutron GL Ltd.  
15 Hoe Chiang Road  
#07-03 Tower Fifteen  
Singapore 089316  
Tel: +65.6220.4666  
Fax: +65.6220.4333  
lutronsea@lutron.com

### EUROPEAN HEADQUARTERS

Lutron EA Ltd.  
6 Sovereign Close  
London, E1W 3JF  
United Kingdom  
Tel: +44.(0)20.7702.0657  
Fax: +44.(0)20.7480.6899

### CUSTOMER SERVICE/ORDERING

USA +1.610.282.3800 –  
08.00 - 20.00 EST  
UK +44.(0)20.7702.0657 –  
09.00 - 18.00 GMT

### CUSTOMER SERVICE /E-MAIL

shadinginfo@lutron.com

### TECHNICAL SUPPORT & SERVICES

USA +1.610.282.3800 –  
24 hours/7 days  
UK +44.(0)20.7702.0657  
09.00 - 18.00 GMT

### INTERNET:

www.lutron.com

### ADDITIONAL LUTRON SALES OFFICES:

#### Germany

Tel: +49.309.710.4590  
Fax: +49.309.710.4591  
FREEPHONE  
00800-5887 6635

#### France

Lutron LTC, S.A.R.L.  
90 rue de Villiers  
92300 Levallois-Perret, France  
Tel: +33.(0)1.41.05.42.80  
Fax: +33.(0)1.41.05.01.80  
FREEPHONE: 0800.90.12.18  
lutronfrance@lutron.com

#### Spain-Madrid

Tel: +34.91.567.84.79  
Fax: +34.91.567.84.78  
FREEPHONE 0900.948.944

#### Spain-Barcelona

Tel: +34.93.496.57.42  
Fax: +34.93.496.57.50  
FREEPHONE 0900.948.944

#### Hong Kong

Tel: +852.2104.7733  
Fax: +852.2104.7633

#### Beijing

Tel: +86.10.5877.1817  
Fax: +86.10.5877.1816

#### Shanghai

Tel: +86.21.6288.1473  
Fax: +86.21.6288.1751

#### Singapore

LUTRON GL Ltd. - Singapore  
15 Hoe Chiang Road  
#7-03 Tower 15  
Singapore 089316  
Tel: +65.6220.4666  
Fax: +65.6220.4333

#### Japan

Tel: +81.3.5575.8411  
Fax: +81.3.5575.8420

### www.lutron.com/shadingsolutions

USA and Canada (24 hrs/7days):

call: 800.523.9466

Other countries (8 a.m. – 8 p.m. ET)

call: +1 610.282.3800

fax: +1 610.282.3090

email: shadinginfo@lutron.com

## Shades Customer Service

USA and Canada (24 hrs/7days):

call: 800.446.1503

©2009 LUTRON Electronics Co., Inc.

Specification Submittal Sheet  
for QS Link power supply

Job Name:	Model Numbers:
Job Number:	